



1070 liter Enopalet tank in a shop selling bulk wine



Mobile plate thermal plate for the Enopalet tank manhole cover



Enopalet – tub model



1070 liter Enopalet tank with Mobilmix removable stirrer

ENOPALET

6.1, 8.3, 10.7, 15.3 hl special palletizable wine-making tanks

Enopalet is a palletizable tank that is a necessity in any wine cellar. It is specifically designed for small capacities and is very handy because it is used to store, transfer and ferment small masses of pressed grapes, must and wines. It can be provided with all possible and handy winemaking accessories. These tanks have large doors for removing the marc after fermentation, conditioning jackets, and all the other accessories used in modern winemaking such as thermometers, temperature probes, mobile or fixed washing plants, designed to mount nitrogen gas inertization systems and also able to use our famous polypropylene "Polifascia" multiple bands or stainless steel thermal bands or fixed TERMOSTAR heat-exchange jackets. Fixed or removable stirrers can be installed. We manufacture palletizable tanks tested to PED 1.3 - 3 - 6 bar for sparkling wines.



Stackable Enopalet tanks from 100 to 1500 litres in size



1000 liter insulated Enopalet tank with nitrogen gas system and 1000 liter "S" series Minitank



Mobilmix removable stirrer for Enopalet tank



610 liter and 1070 liter Enopalet tank for micro-fermentations

Stainless steel ladder for Enopalet tank



600 liter Enopalet tank with air float

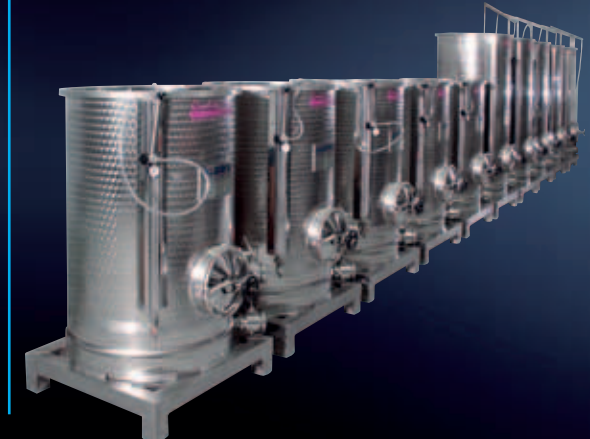

Dia. 400 manhole cover for Enopalet tank with safety unit for nitrogen

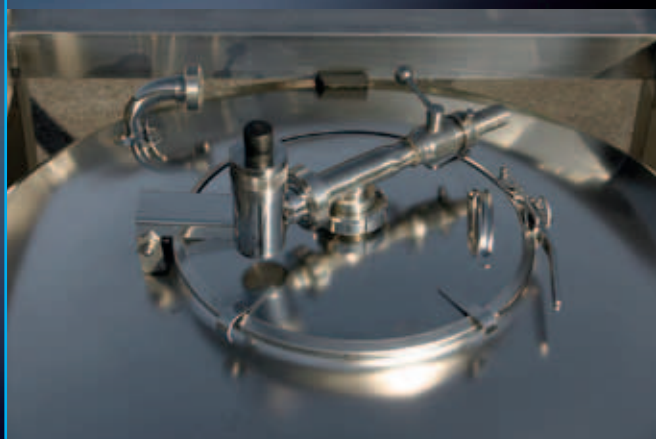

Topclean washing ball

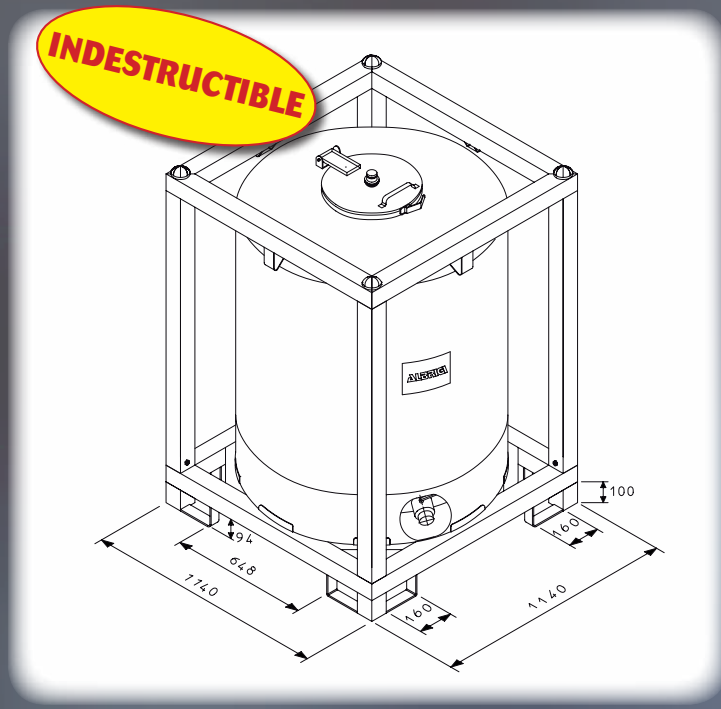

Paletank – stackable to 5 pieces and transportable on all types of transpallets and fork lifts

a friend in the wine cellar



1000 and 1500 liter Enopalet tanks with pneumatic variable-capacity cover



610 liter Enopalet tank with multiple band



1000 liter Enopalet tank, 1.5 bar PED tested with accessories



1530 liter Enopalet tank with rectangular door and conditioning jacket, with thermometer and temperature probe and 2 valves, ideal for micro-fermentations



1070 liter Enopalet tank with stainless steel temperature-controlled thermal band jacket that can be installed on existing palletizable tanks



1000 liter totally insulated Isopalet tank for refrigerated wines



Digital thermometer

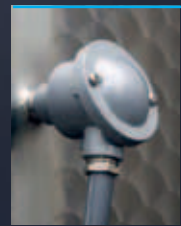

Probe carrier for temperature control



Sampling device



830 liter Enopalet tank with dia. 400 round hatchway

Stainless steel protected total drain valve for Enopalet tank



Shallow pressed total drain bottom



Stackable Enopalet tanks, sizes 610, 830, 1070, 1530 liters