



Centrifugal Sanitary Pumps

CS - CSX series

Standard design

Closed coupled hygienic centrifugal pumps with open impellers. CS Series pumps meet the highest requirements of the food, pharmaceutical, chemical and water treatment industries. The pumps are designed to a modular concept, resulting in a large number of models and a massive performance range. When combined with the extremely robust construction, these highly efficient pumps become ideal for any hygienic process system.

Wetted parts in CF-3M 1.4404 / AISI 316L stainless steel, investment cast and electro-chemically polished. Special internal finishes to 0,5 micron Ra are available on request (not on sizes 125 to 150).

Separate IEC standard motor.
Flow rates up to 500 m³/h, heads up to 100 m (10 bar); high performance, with low NPSH values.

The clamp casing and seal design allows quick disassembly for inspection, cleaning and maintenance. It also enables the delivery port to be rotated to any position for easy installation (not on sizes 125 to 150).

For aggressive products and environments, CS pumps can on special request, be manufactured in the following materials:

- Sanicro 28 (1.4563)
- Duplex SAF 2507 (1.4410)
- Hastalloy C276

Seals:

Mechanical seals with seats to EN 12756, ISO 3069 standards.
Single internal mechanical seal
Single external mechanical seal
Double flushed mechanical seal

Elastomers (certified to FDA):

EPDM
Fluorocarbon (Viton)
Silicone
P.T.F.E. (Fep)

Connections:

DIN - SMS - IDF - BS / RJT - DS - CLAMP and EN 1092-1 PN 16 flanges suitable for all international standards.



CS pump with shroud and adjustable feet.



CSD aseptic pump
Ideal for sterile products.



CS pump X execution
Close coupled centrifugal pumps with separate support frame and grease lubricated bearings, for extremely arduous applications.



Special version equipped with an inducer in the suction port. This device is fitted immediately upstream of the impeller to reduce the NPSH required by the pump.

A wide range of 27 models divided into 4 groups.

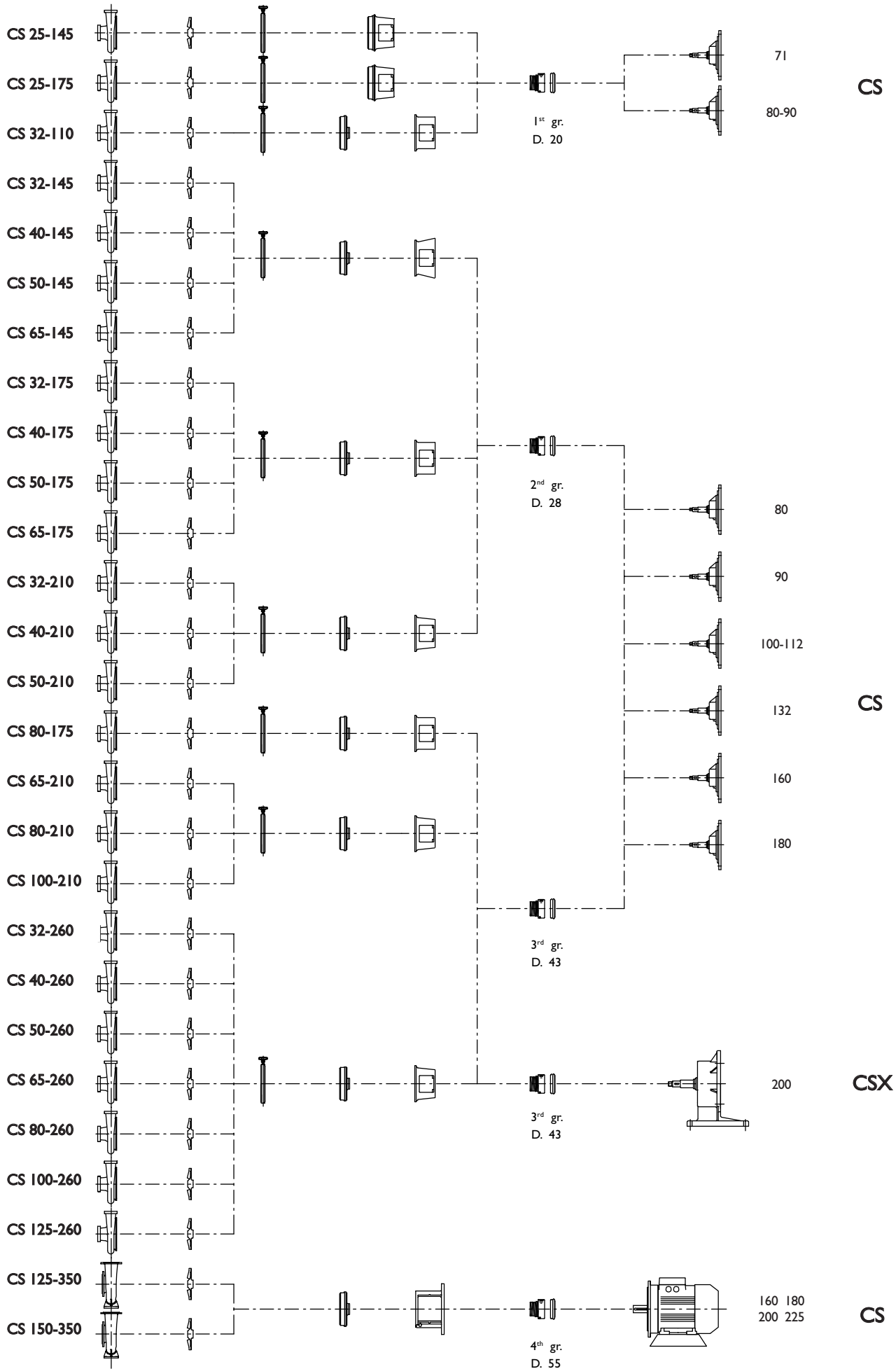

GENERAL DIAGRAMS

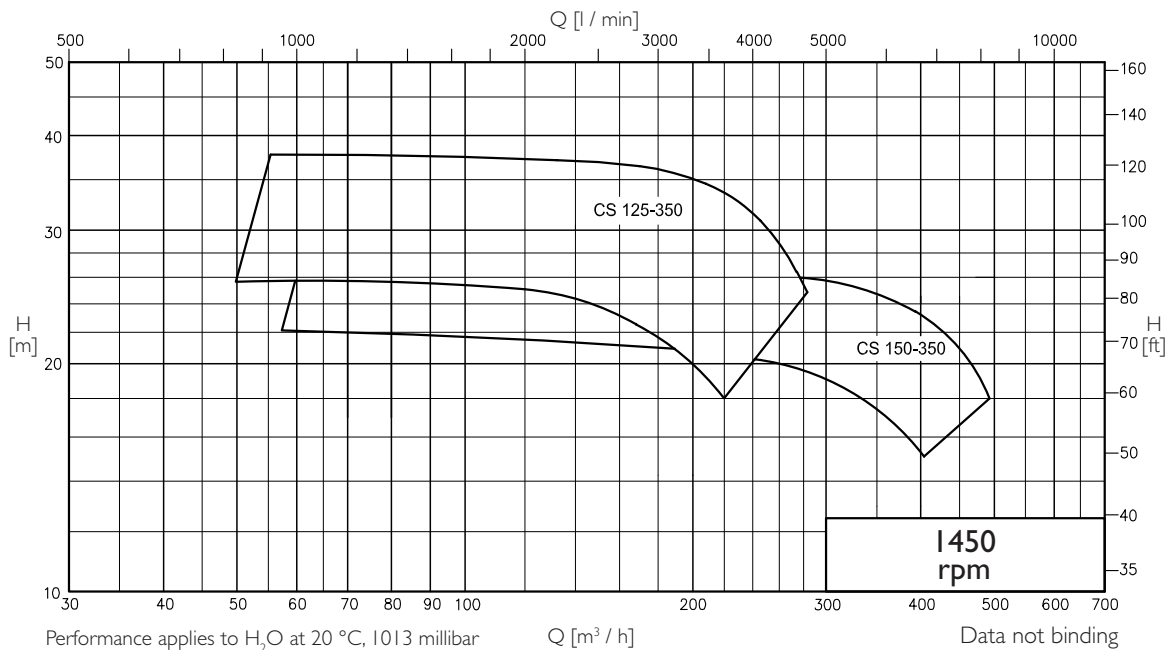
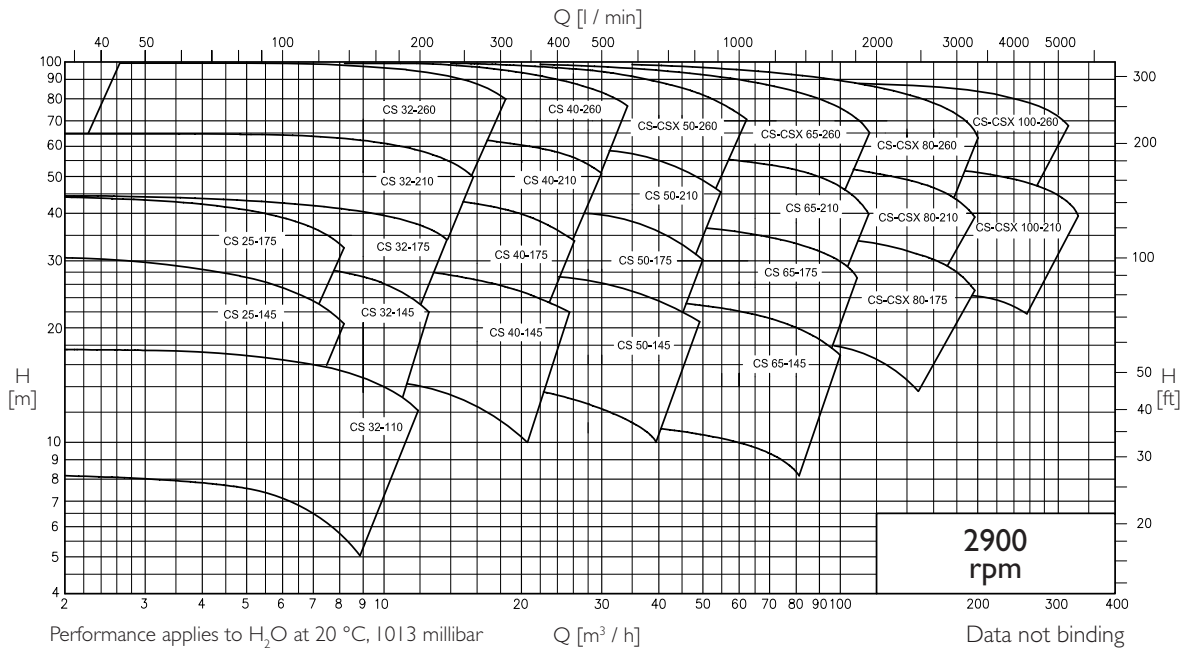
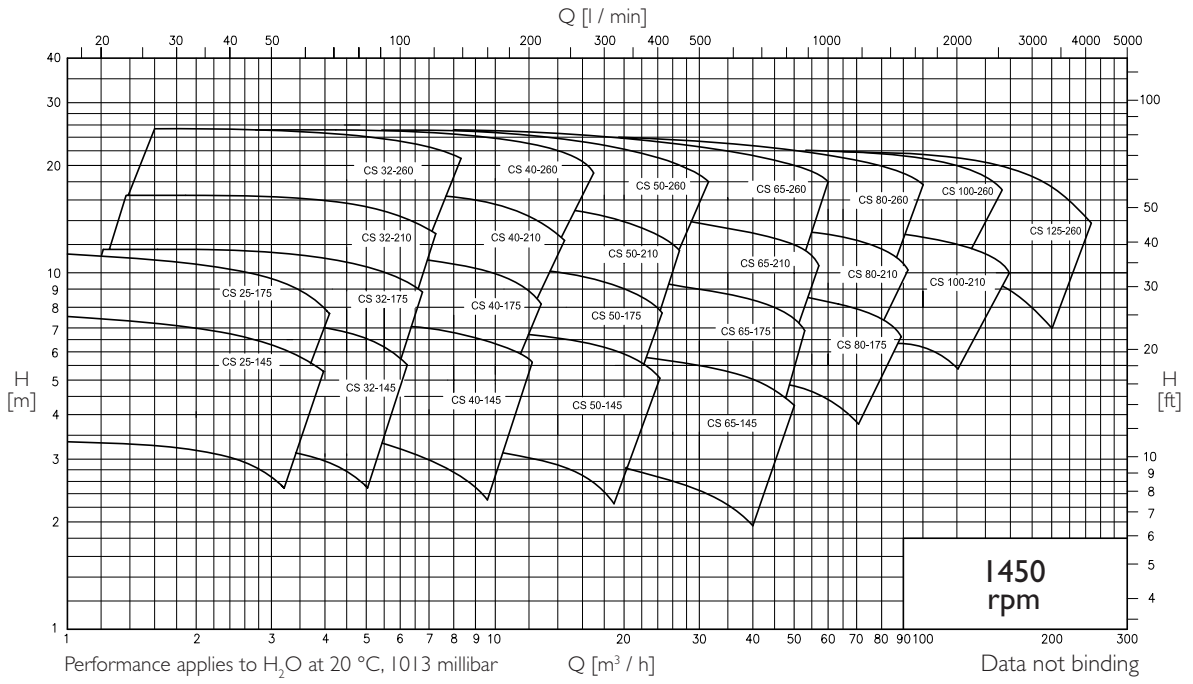

OVERALL DIMENSIONS

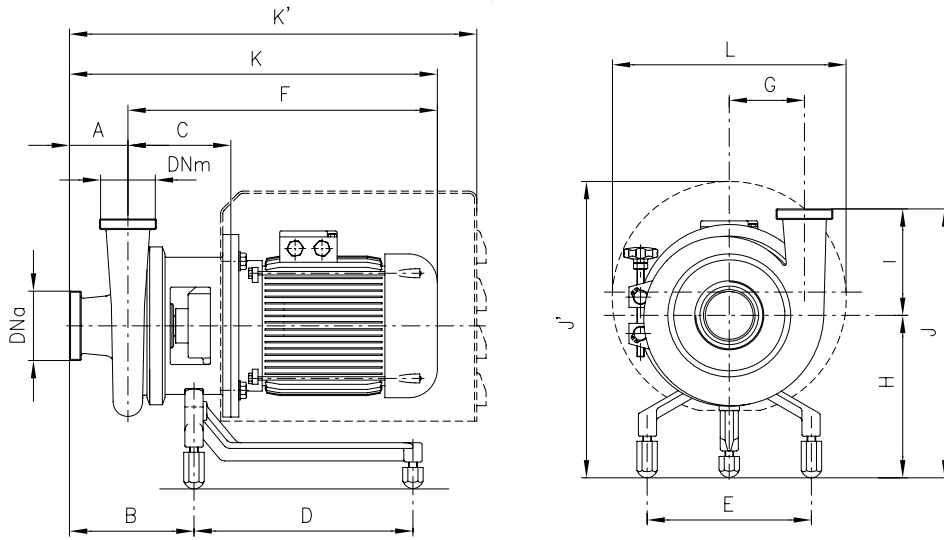

Dimensions not binding - DN = DIN 11851 male threaded connections with standard IEC/EN motors

Pumps	IEC motors size:	DNa	DNm	A	B	C	D	E	F	G	H	K	K'	I	J	J'	L
CS 25-145	71	32	25	75	144	117	190	178	327	81	158	402	534	145	303	295	239
	80					432											
	90					479											
CS 25-175	71	32	25	65	134	117	190	178	327	96	164	392	525	149	313	301	239
	80					422											
	90					469											
	100					523	210	536	601		359	381	298				
	112					471		458	471		553						
CS 32-110	71	40	32	70	137	117	190	178	327	65	149	397	530	110	259	286	239
	80					427											
	90					404						474					
CS 32-145	80	40	32	80	167	138	231	225	372	85	208	452	566	145	353	372	298
	90					499											
	100					451	225				531	636	370		389		
	112					473					553						
CS 32-175	80	40	32	80	167	139	231	225	373	95	213	453	567	150	363	377	298
	90					500											
	100					452	230				532	637	380		394		
	112					473					553						
CS 32-210	80	40	32	80	158	139	231	225	373	110	221	453	567	165	386	385	298
	90					500											
	100					452	238				532	637	403		402		
	112					473					553						
CS 32-260	90	50	32	90	184	163	231	225	444	140	221	534	601	172	393	385	298
	100					476						566					
	112					497	587										
CS 40-145	80	50	40	80	168	139	231	225	373	90	208	453	567	133	341	372	298
	90					501											
	100					452	225				532	637	358		389		
	112					473					553						
CS 40-175	80	50	40	80	169	141	231	225	375	95	213	455	569	150	363	377	298
	90					502											
	100					454	230				534	639	380		394		
	112					475					555						
CS 40-210	80	50	40	80	161	141	231	225	375	115	221	455	569	165	386	385	298
	90					502											
	100					454	238				534	639	403		402		
	112					475					555						
CS 40-260	90	50	40	100	194	163	231	225	444	145	221	544	611	172	393	385	298
	100					476						576					
	112					497	597										
CS 50-145	80	65	50	80	170	141	231	225	374	95	208	454	569	145	353	372	298
	90					502											
	100					454	225				534	639	370		389		
	112					475					555						
CS 50-175	80	65	50	80	169	141	231	225	374	100	213	454	569	150	363	377	298
	90					502											
	100					454	230				534	639	380		394		
	112					475					555						
CS 50-210	90	65	50	80	161	141	231	225	422	120	221	502	569	165	385	385	298
	100					454						534					
	112					475	555										
CS 50-260	100	65	50	90	185	165	301	225	477	145	238	567	672	175	413	402	298
	112					498						588					
CS 65-145	80	80	65	79	173	145	231	225	379	112	208	458	572	145	353	372	298
	90					505											
	100					458	225				537	642	370		389		
	112					479					558						
CS 65-175	90	80	65	80	172	144	231	225	425	120	213	505	572	150	363	377	298
	100					457						537					
	112					478	558										
CS 65-210	90	80	65	90	189	168	231	225	449	135	221	539	605	165	386	385	298
	100					481						571					
	112					502	592										

CS 65-260	100	80	65	100	198	168	301	225	480	155	238	580	685	205	443	402	298
	112								501			601					
CS 80-175	100	100	80	100	204	174	301	225	486	139	230	586	691	164	394	394	298
	112								507			607					
	160								537			637					
CS 80-210	100	100	80	100	201	171	301	225	483	145	238	583	688	165	403	402	298
	112								504			604					
	160								534			634					
CS 80-260	100	100	80	100	201	171	301	225	483	165	238	583	688	209	447	402	298
	112								504			604					
	160								534			634					

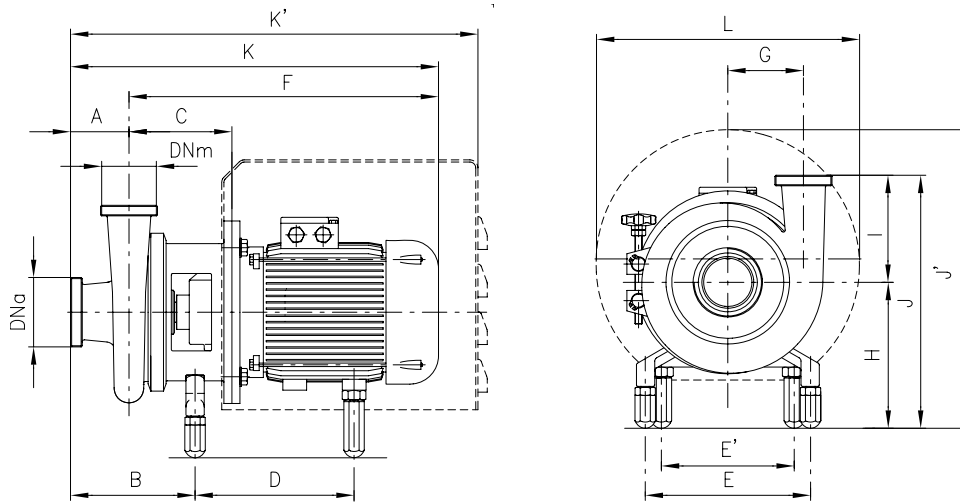

Dimensions not binding - DN = DIN 11851 male threaded connections with standard IEC/EN motors

Pumps	IEC motors size:	DNa	DNm	A	B	C	D	E	E'	F	G	H	K	K'	I	J	J'	L	
CS 32-210	132 M-S	40	32	80	158	161	298	225	115	534	110	238	614	680	165	403	455	370	
	132 MB					206	430		140	578			658	735			494	430	
	160					206	430		140	684			764	935					
CS 32-260	132 M-S	50	32	90	184	185	307	225	115	558	140	238	648	714	172	410	455	370	
	132 MB					225	434		140	581			692	769			419	507	430
	160					225	434		140	703			793	967					
CS 40-175	132 M-S	50	40	80	169	164	290	225	115	537	95	230	617	682	150	380	447	370	
	132 MB					161	208		422	140			581	661			737	486	430
	160					161	208		422	140			686	766			937		
CS 40-210	132 M-S	50	40	80	161	164	298	225	115	537	115	238	617	682	165	403	455	370	
	132 MB					208	430		140	581			661	737			494	430	
	160					208	430		140	686			766	937					
CS 40-260	132 M-S	50	40	100	194	185	307	225	115	558	145	238	658	724	172	410	455	370	
	132 MB					225	434		140	602			702	779			419	507	430
	160					225	434		140	703			803	978			579	420	
180	225	532	279	785	885	1094													
CS 50-145	132	65	50	80	170	164	289	225	115	537	95	225	617	682	145	370	442	370	
CS 50-175	132 M-S	65	50	80	169	164	291	225	115	537	100	230	616	682	150	380	447	370	
	132 MB					208	422		140	581			661	737			486	430	
	160					208	422		140	686			766	937					
CS 50-210	132 M-S	65	50	80	161	164	298	225	115	537	120	238	617	682	165	403	455	370	
	132 MB					208	429		140	581			661	737			494	430	
	160					208	429		140	686			766	937			580	420	
	180					171	223		532	279			783	863			1072	413	580
CS 50-260	160	65	50	90	186	228	434	225	140	706	145	247	796	970	175	422	507	430	
	180					228	532		279	788			878	1087			579	420	
	180					228	532		279	788			878	1087					
CS 65-145	132 M-S	80	65	79	173	168	289	225	115	541	112	225	620	685	145	370	442	370	
	132 MB					212	420		140	585			664	740			481	430	
	160					212	420		140	690			769	940					
CS 65-175	132 M-S	80	65	80	172	167	290	225	115	540	120	230	620	685	150	380	447	370	
	132 MB					211	422		140	584			664	740			486	430	
	160					211	422		140	689			769	940			573	420	
	180					173	224		531	279			784	864			1073	391	573
CS 65-210	160	80	65	90	189	231	434	225	140	709	135	247	799	974	165	412	507	430	
	180					231	532		279	791			881	1090			579	420	
	180					231	532		279	791			881	1090					
CS 65-260	132 M-S	80	65	100	198	190	307	225	115	563	155	238	663	728	205	443	455	370	
	132 MB					230	434		140	607			707	783			507	430	
	160					230	532		279	708			808	983			579	420	
	180					230	532		279	790			890	1099			452	455	370
CS 80-175	132 M-S	100	80	100	204	195	307	225	115	568	139	230	668	734	164	405	447	370	
	160				205	432	140		714	814			989	497			430		
	180				205	531	279		796	896			1105	573			420		
CS 80-210	132 M-S	100	80	100	193	307	225	115	566	145	238	247	666	731	165	403	455	370	
	160				233	434		140	711				811	986			507	430	
	180				233	532		279	793				893	1102			579	420	
CS 80-260	132 M-S	100	80	100	193	307	225	115	566	165	238	247	666	731	209	447	455	370	
	132 MB				233	434		140	610				710	786			507	430	
	160				233	434		140	711				811	986			579	420	
CS 100-210	132	125	100	111	219	200	307	225	115	573	161	238	683	750	214	461	455	370	
	180				240	532	279		800	911			1120	579			420		
	132 MB				195	307	115		612	727			803	454			455	370	
CS 100-260	160	125	100	115	218	235	434	225	140	713	186	247	828	1004	216	463	507	430	
	180				235	532	279		795	910			1118	579			420		
	132 MB				203	307	115		620	730			806	454			455	370	
CS 125-260	160	150	125	110	223	244	434	225	140	722	206	247	832	1007	216	463	507	430	
	180				244	532	279		804	914			1102	579			420		
	180				244	532	279		804	914			1102						

OVERALL DIMENSIONS

**PUMPS CSX SERIES
FOR POWER OF 30 kW
(MOTOR SIZE IEC 200)**

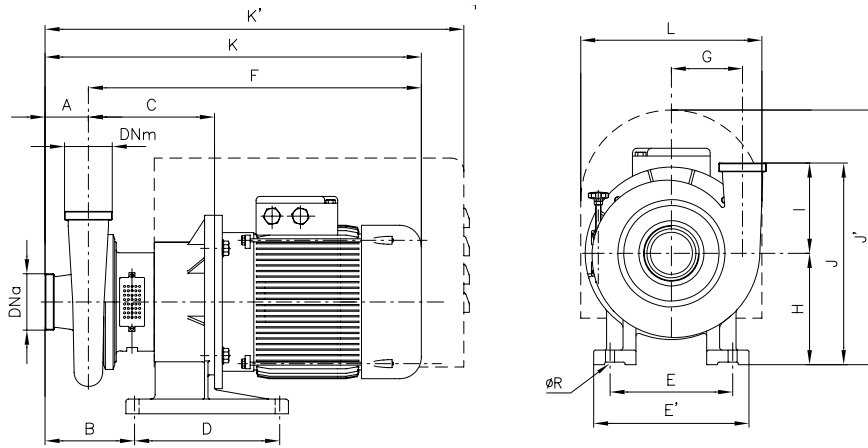

Dimensions not binding - DN = DIN 11851 male threaded connections with standard IEC/EN motors

Pumps	IEC motor size 200	DNa	DNm	A	B	C	D	E	E'	F	G	H	K	K'	ØR	I	J	J'	L
CSX 50-260		65	50	90	201	296	335	284	360	856	145	258	952	1087	21	175	433	590	420
CSX 65-260		80	65	100	213	298	335	284	360	858	155	258	958	1099	21	205	463	590	420
CSX 80-175		100	80	100	219	304	335	284	360	864	139	258	964	1105	21	164	422	590	420
CSX 80-210		100	80	100	216	301	335	284	360	861	145	258	961	1102	21	164	422	590	420
CSX 80-260		100	80	100	216	301	335	284	360	861	165	258	961	1102	21	209	467	590	420
CSX 100-210		125	100	111	234	308	335	284	360	868	161	258	979	1120	21	214	472	590	420
CSX 100-260		125	100	115	233	303	335	284	360	863	186	258	978	1119	21	216	474	590	420
CSX 125-260		150	125	110	237	312	335	284	360	872	206	258	982	1123	21	216	474	590	420

**"CS" PUMP
4th GROUP
CLOSE COUPLED
VERSION**

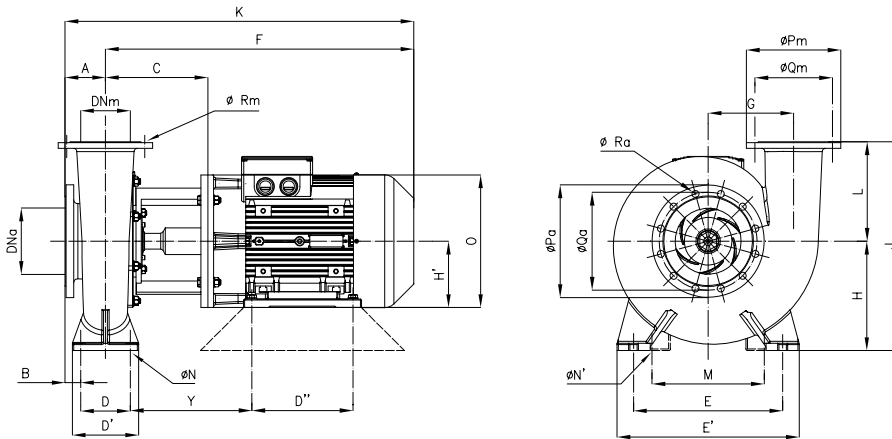

Dimensions not binding - DN = Flanges EN 1092-1 PN 16

Pumps	IEC motors size:	DNa	DNm	A	B	C	D	D'	D''	E	E'	F	G	H	H'	K	J	Y	L	M	N	N'	O	Ø Pa	Ø Pm	Ø Qa	Ø Qm	Ø Ra	Ø Rm	no. holes a	no. holes m				
CS 125-350	132	150	125	122	47	286	150	200	279	400	500	846	232	280	180	968	580	332	300	279	22	12	300	285	250	240	210	22	18	8	8				
	160																															319	254	17	350
	180																															361	318	19	400
	200																															407	356		450
	225																																		
CS 150-350	132	200	150	122	47	292	150	200	279	450	550	852	258	330	180	974	630	338	300	279	22	17	350	340	285	295	240	22	22	12	8				
	160																															361	318	19	400
	180																															407	356		450
	200																																		
	225																																		



CSF Inox S.p.A. Strada per Bibbiano, 7 - 42027 Montecchio E. (RE) - ITALY EU
Ph +39.0522.869911 r.a. - Fx +39.0522.865454 / 866758 - csfitalia@csf.it - www.csf.it

Export Department • Commercial Étranger • Comercial Extranjero

Ph +39.0522.869922 - Fx +39.0522.869841 - csfexport@csf.it - www.csf.it